

SALAMANDER LADLE LINERS

- ✓ **CLEAN, GAS FREE METAL**
- ✓ **LONG LIFE, NO PATCHING**
- ✓ **EASY TO FIT**

The liner should be set in the steel shell with Trimor Insulcast, which is a good insulator and sets firmly.

MIXING TRIMOR® INSULCAST

Mix only sufficient for the job at hand
 Mix with water – four parts by weight of Insulcast, to one part water

VENTING THE LADLE

1. Ladle shells should be vented to ensure the release of moisture from the Insulcast. Shells with a capacity less than 150 Kg should have four 6mm holes in the base (Including one in the centre) and four around the side, well-spaced out. Shells with a capacity above 150Kg should have five 6mm holes in the base and six around the side.
2. The setting material should be vented using two lengths of string or "spun yarn" tied vertically around the liners so as to make four vents, or for liners over 150 Kg capacity, three lengths to make six vents.

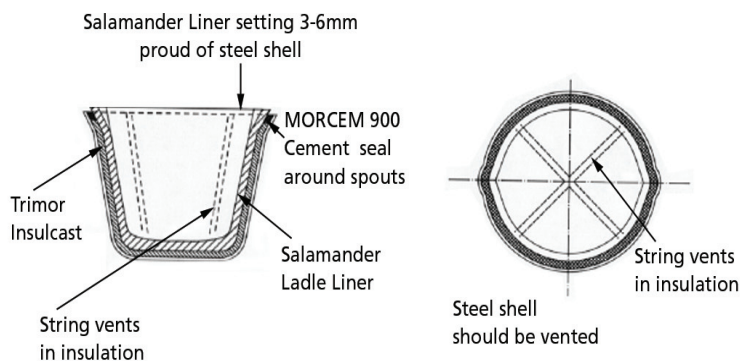

ASSEMBLY OF SALAMANDER LINERS IN STEEL LADLES



INSTALLING THE LINER

1. Place a thick layer of Insulcast in the bottom of the shell.
2. Bed the liner down firmly, squeezing the setting material up the sides until the liner is level with the bottom of the shell.
3. Ram more Insulcast down from the top all around, so that the liner is firmly supported. The liner will rise during ramming, and should finish up 3 – 6mm above the top of the shell.

DRYING THE LADLE

1. The refractory materials should be allowed to air-set over night.
2. Dry thoroughly for several hours, by torch or in an oven.
3. Seal the joint between ladle and liner around the pouring spouts only, with 12mm depth of Salamander Morcem 900 mixed with water to a putty consistency. Do not seal the vents.
4. Thoroughly pre-heat cold ladles, as usual, before use.

WARNING

It is dangerous to pour molten metal into a newly lined ladle, which has not been properly dried. New ladles should not be filled until all emission of steam has ceased and the liner should be sufficiently hot to char a piece of paper

Salamander Super clay graphite ladle liners are available in the following sizes and can also be supplied with bottom pour arrangement (riser tube and cover plate).

Salamander Clay Graphite	Top Diameter (mm)	Height (mm)	Bottom Diameter (mm)	Brass Capacity (Kg)	Brimful Capacity (Litres)
L415	181	187	130	19	2.4
LLG60	200	205	160	22	2.9
LLG100	235	240	205	42	5.5
L417	241	257	162	46	5.8
LLG150	260	265	230	53	7.1
L457	305	241	214	76	9.7
LLG200	300	290	250	76	10.2
L266	314	266	214	89	11.3
L458	324	289	214	91	11.6
LLG250	305	320	265	93	12.4
LLG300	330	330	285	117	15.6
LLG350	330	355	285	127	16.9
LLG400	355	370	310	159	21.2
LLG500	395	395	350	207	27.5
LLG600	405	425	350	231	30.7
LLG1000	485	500	425	413	54.9
LLG1500	545	560	465	560	74.5
LLG2000	610	635	535	855	113.8
LLG3000	685	710	595	1177	156.6

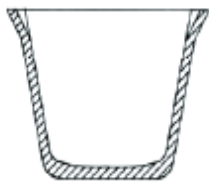

Standard

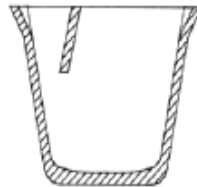

With riser tube



With riser tube and cover plate

The following sizes are available as Excel silicon carbide ladle liners and also with bottom pour arrangement (riser tube and cover plate).

Salamander Excel Silicon Carbide	Top Diameter (mm)	Height (mm)	Bottom Diameter (mm)	Brass Capacity (Kg)	Brimful Capacity (Litres)
LX441	340	329	221	121	15.4
LX482	360	385	214	147	18.7
LX456	432	442	311	284	35.8
LX483	466	541	386	441	56.1
LX481	565	578	474	725	92.0
LX751	626	692	556	1100	140.8

Notes

1. Pattern L, LB & LT are Salamander Super clay graphite
2. Pattern LX, LBX & LTX are Salamander Excel carbon bonded silicon carbide
3. Working capacity is calculated as 90% of the brimful capacity when melting brass, specific gravity 8.75



For additional information on Morgan MMS' products & services or to find a location nearest to you, please visit: www.morganmms.com