

Electric Fusion Furnace Model EMF-E

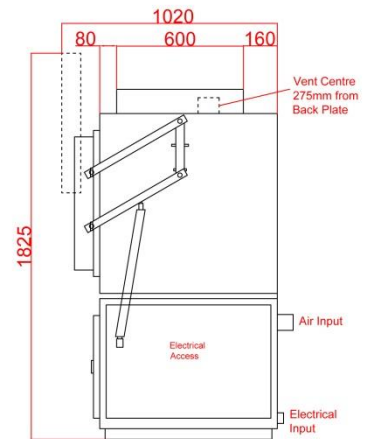
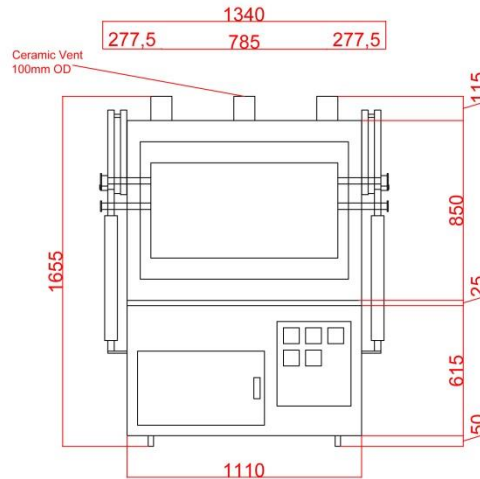

Key Benefits

- Uses a No. 7 Muffle.
- Takes 25 x 50g and 65gram, or 36 x 30g or 30 x 40g and 55gram Crucibles.
- Easy to maintain and operate.
- Compatible with "Multi-pour" loading / unloading system
- Built to Industry Standards

Technical Specifications

Construction

- Cabinet is 2 mm zinc anneal sheet steel, lined with fire bricks and backed with Superwool insulation board.
- The furnace is mounted on a console fabricated from 2mm zinc anneal sheet and finished in Hammerfin blue enamel.

Internal Dimensions

- No. 7 Muffle 300 mm high x 600 mm wide x 580 mm deep.

Electrical Requirements

- 24kw, 3 Phase. (NOTE: Voltage is customised to destination country of the furnace).

Heating Elements

- 12 x Silicon carbide elements rated at 24 K.W. Total, 3 phase.
- Power supply to the elements is per a multi-tapped double wound transformer.

Temperature Control

- Electronic, Automatic control.
- Type K Thermocouple.
- High Temperature Alarm output
- Fitted with a 7 day timer.
- Fitted with Over Temperature Controller

Door Operation

- Pneumatic rising. Operated by foot control.

Reproduction of this document or any part thereof without the written consent of Furnace Industries is not permitted and will be an infringement of Furnace Industries copyright.